

Non-Isothermal Water Vapour Transmission through Porous Insulation. Part 1: The Climate Chamber

Tim Padfield, PhD*

Ruut Peuhkuri, MSc†

Carsten Rode, Associate Professor†

Kurt Kielsgaard Hansen, Associate Professor†

1. INTRODUCTION

The standard data for permeability to water vapour of building materials are mostly derived from the steady state 'cup method' (CEN 2001). For highly porous materials, such as fibrous insulation, the value measured in this way is mostly attributable to diffusion through the linked air spaces and takes no account of moisture absorption during changing gradients of temperature and water vapour concentration, which is the natural environment of building materials. The apparatus described here is designed to give direct measurements of the effects of linked diffusion and sorption in a continuously changing environment.

2. THE CLIMATE CHAMBER

2.1 Principles of operation

The chamber is a cylindrical well with an inner surface of stainless steel, which is a moisture inert material. The material under test is laid horizontally over the top. It can be a single layer of porous material or a complete section of wall or roof, The edges of the specimen are sealed against vapour movement. The specimen is enclosed by a ring of impermeable insulation which is sealed against a flange extending outwards from the top of the well (figure 1). Water vapour transmission and most of the heat transmission are limited to the area of the specimen under test, which can be up to 800 mm diameter.

The moisture diffusion through the specimen is either measured or defined by a device within the well which absorbs or emits water vapour at a controlled rate. The dew point and temperature are measured on both sides of the specimen and may also be measured at points within the specimen. In this way one can measure the water vapour flux through a specimen, and the resulting relative humidity at points within the specimen, under gradients of relative humidity and temperature.

The experiment is usually conducted with colder air in the well than in the enclosing room, so that convective air movement through the specimen is suppressed. This is an unnatural situation for a wall, but it simplifies interpretation. Processes involving streaming air, though a common cause of unexpected failures in building envelopes, are not so amenable to modelling. Our view is that we should first understand the diffusive processes. The unresolved issues are discussed in part 2.

* Conservation Department, The National Museum, Brede, DK-2800 Kgs. Lyngby, Denmark.

† Department of Civil Engineering, Technical University of Denmark, Building 118, DK-2800 Kgs. Lyngby.

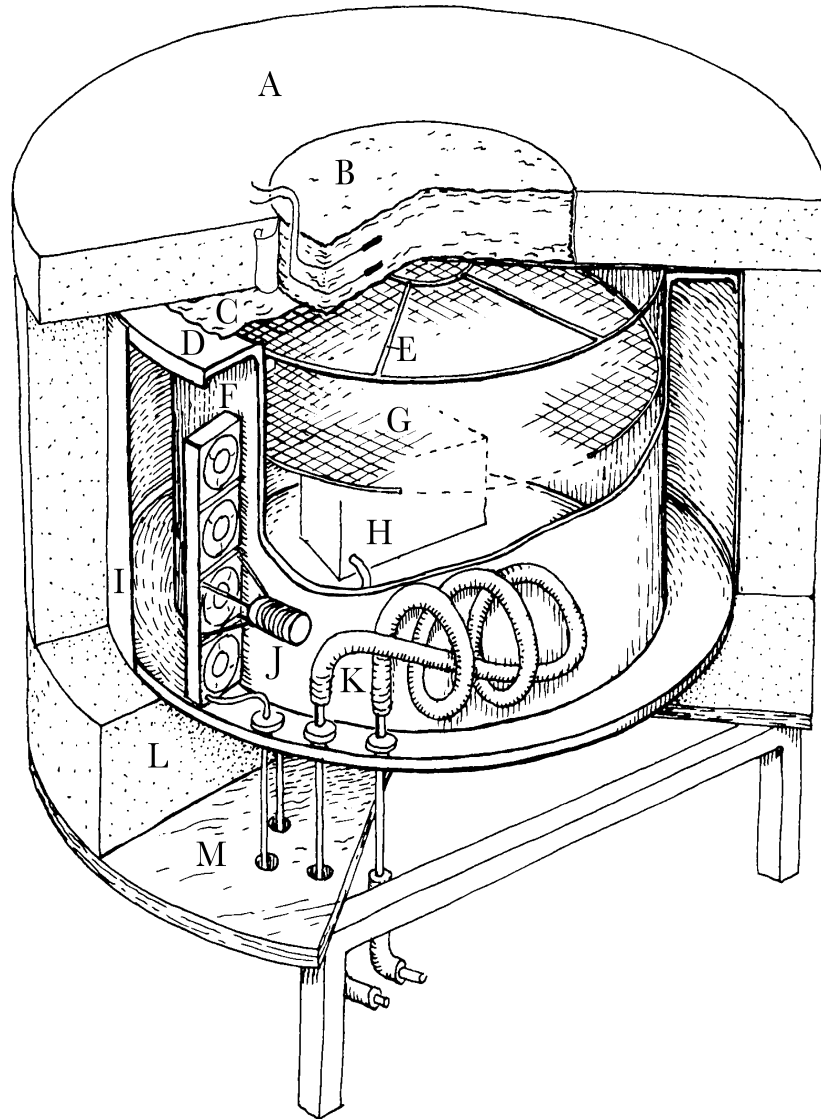

Figure 1

A cutaway perspective drawing of the climate chamber. The specimen B is mounted over the top of the chamber. It is surrounded by insulation A. Vapour passage is restricted to the specimen by vapour barriers C arranged around the specimen and under the insulation and extending over the flange D. The specimen is supported by the open grid E, supplemented if necessary by a permeable, non-woven fabric. The grid G calms the air movement over the specimen surface. It can also be used to support a specimen entirely within the chamber, which can be sealed with a metal lid bolted to the flange D which has threaded holes and an o-ring seal.

The temperature of the chamber is controlled by air circulating in the annular space formed by the chamber wall, the top and bottom flanges and the thin aluminium wall I. Heating is by the electric resistance J; cooling is by water circulating in coil K. The air is vigorously pushed round by the fans F. The water vapour content of the chamber is controlled by unit H, which is described in figure 2. All services are sealed through the base of the chamber. The chamber is supported on 200 mm of dense extruded polystyrene L, which rests on a low table M.

The unique feature of this chamber, compared to a standard climate chamber, is that it keeps account of the amount of water vapour absorbed from, or released to, the air in the chamber. It can also define a water vapour flux into the air space, which will then be absorbed into, or transmitted through, the specimen. The observed relative humidity in the chamber is the consequence of the movement of water vapour, not the cause.

2.2 The construction of the chamber

The climate chamber is a cylinder of stainless steel, 790 mm diameter and 500 mm deep. A 120 mm flange extends out from the top. The base plate extends out an equal amount beyond the wall. The side is 4 mm thick, the flange and the base plate are 6 mm. The chamber rests on 200 mm of dense extruded polystyrene insulation. A second wall of 1 mm aluminium sheet, is sealed to the edges of the flanges to form an annular chamber. This is covered with 100 mm of flexible insulation.

2.3 Temperature control

The temperature of the well is controlled by air circulating in the annular space. The entire wall temperature is controlled and uniform, which allows the chamber to maintain a high relative humidity (RH) without condensation. The upper limit to the RH at the lower surface of the test specimen depends on the heat transfer through the specimen and on the efficiency of heat transfer from the surface to the wall. As a rough rule, a wall temperature one degree below the specimen surface temperature will allow a maximum RH at the specimen surface of 93%, because the RH at the wall will be 96%, which is the maximum RH which does not risk causing condensation with the slightest transient variation in temperature. This would completely destroy the flux measurement (described below), which depends on condensation only occurring in one particular place. If it is essential to hold a very high RH, the specimen area can be reduced, to reduce the heat flow.

The temperature difference between the specimen surface and the wall can also be reduced by vigorous air circulation, but this will cause transient local pressure differences that press moisture through the specimen and give an unrealistic description of the behaviour of the specimen in its natural habitat. The well is therefore fitted with supports for an air-calming grid which separates the vigorous air circulation around the moisture controlling device from the air adjacent to the specimen, whose circulation can be controlled independently.

This grid also serves another purpose. It can hold a specimen entirely within the chamber, while a steel lid is bolted down over the o-ring on the flange. This arrangement allows experiments where the specimen is exposed to the same climate on both sides, or is sealed at the back. These would typically be tests of the humidity buffering performance of interior finishes.

The chamber operates in an air conditioned room but it has been designed to allow the addition of an upper chamber with independent air conditioning, so that the specimen can be sandwiched between two tightly controlled, independently adjustable climates.

2.4 Temperature control within the annular space

The air in the annular space is cooled by water circulating in a ribbed copper coil of 30 mm tube diameter and about 3m long. The air is heated by an electric resistive element. There is a tube to allow a slow flow of dry air into this space, to prevent condensation on the cooling surface. The air is circulated vigorously by a group of four fans which almost span the annular area. This arrangement gives an even temperature at the inner surface of the well, uniform to better than one degree. The floor of the well is not directly controlled, just insulated.

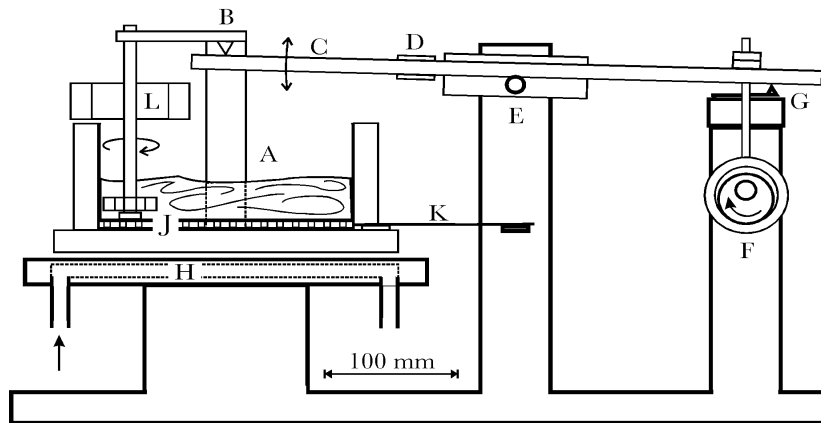

Figure 2 The water vapour controller. Vapour is evaporated from, or condensed into, the copper tank A. The temperature of the tank is controlled by the thermoelectric heat pump J, energised through two flat spring conductors K. The water is stirred by the wind driven propeller L. This assembly normally rests on the heat sink H, whose temperature is controlled by a sealed circulating water system. The tank is weighed at intervals by turning the cam F which pivots the beam C about the fulcrum E. This raises the tank 2 mm above the heat sink, suspended from two sharp points B. The springs K hold the tank steady. The measured deflection of the strain gauge bridge D is proportional to the weight of the tank assembly. After weighing, the cam F is turned again until microswitch G breaks the circuit, thus ensuring that the beam returns to the relaxed position with the tank resting on the heat sink and the points B just clear of the beam. The tank holds about 200 ml of water, which can be periodically removed, or replaced, through a fine tube dipping into the tank.

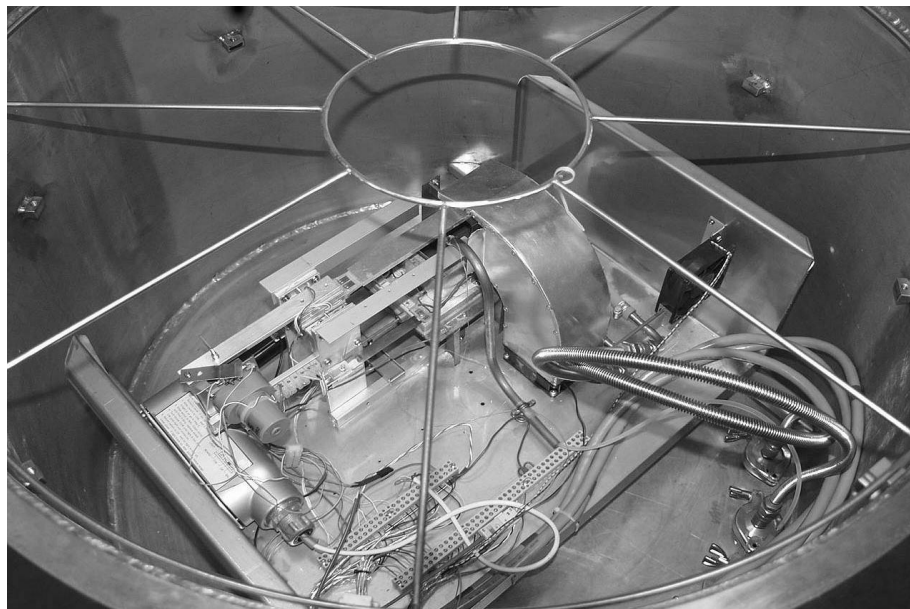

Figure 3 A view of the humidity controller in the well. The curved duct brings an airstream which stirs the water and forces air over the water surface. The steel tray can be raised for servicing, without undoing the flexible couplings for water and electrical services. (Photo: Christian Bramsen)

2.5 The humidity controller

The humidity controller (figure 2) is entirely within the well. The relative humidity, or the water vapour flux, is controlled by absorbing water into, or evaporating water from, a small copper tank with insulated sides, whose temperature is controlled by a thermoelectric (Peltier) device fixed beneath the tank.

The thermoelectric element is a heat pump which establishes a temperature difference between two parallel ceramic plates held a few millimetres apart by the series of semiconductor junctions which generates the heat flow. Reversing the current direction reverses the heat flow. When the plate which is touching the water tank is cold, to condense water into the tank, the warm side away from the tank has to be cooled. The temperature of this side is controlled by contact with a heat sink whose temperature is controlled by a sealed circulating water supply at two degrees above the dew point of the air in the well. Water vapour will only condense into the tank, because it is the coldest place in the entire chamber. If the tank is warmed to evaporate water, the thermoelectric element will try to cool the heat sink, but the circulating water will still hold it above the dew point temperature.

The circulating water tubes pass through the bottom of the well to a remote reservoir which is held at the correct temperature. This reservoir only needs to be cooled, because the circulation pump provides compensating heat to allow sufficiently rapid response to the load.

2.6 Measuring the water vapour flux

The water vapour flux to and from the tank is measured by weighing the tank. The tank is suspended from a beam which normally allows it to sit on the heat sink. The air circulation fan is stopped a few seconds before weighing, then a lifting mechanism pivots the beam so that the tank rises 2 mm above the heat sink. The beam has strain gauges to measure its deflection. The beam is lowered after the measurement, which takes about five seconds, according to the precision required. The measurement is generally repeated once per minute, but that depends on the demands of the particular experiment. The short period of bending reduces the creep of the beam, so the weight measurement remains stable over time. The effect of temperature on the weight measurement is compensated by calculation in the controlling computer program. The gauges are covered by paraffin wax and are unresponsive to RH.

The thermoelectric unit is weighed together with the tank, because it must be in good thermal contact, helped by a heat conducting paste. Electric power must be continually applied to the thermoelectric device, otherwise the thermal expansion stresses will eventually destroy it. The electricity supply is brought in through thin stainless steel springs which are approximately horizontal when the beam is raised. The springs are held in slight tension, by slightly unbalancing the tank about its suspension point. This stabilises the tank as it is raised.

3. CONTROLLING THE CLIMATE

3.1 Data collection

The climate in the well is measured by a Hewlett Packard data logger. This measures temperatures, strain, and various voltages. The scientifically important data are the weight change of the tank, the temperature and the dew point of the air in the well. The data logger also measures other temperatures and voltages, which are used to control the climate and to detect malfunctions that could damage the experiment or the apparatus.

3.2 The climate control program

The control program is written in the Python scripting language and runs under Linux. There is a serial connection to the data logger. Once a minute, or at any longer interval that may be chosen, the program initiates the measuring sequence, analyses the returned raw data, refines and stores the results. The program then sends control instructions back through the same data logger, using its relay closure card. These low power relays control valve actuators and high power relays which activate cooling water, heaters and fans.

The control of the water vapour flux is more complicated. The program calculates a voltage for the thermoelectric heat pump. This is only allowed to change quite slowly, to avoid thermal stresses on the device. The voltage is digitised and then sent via the relay card to a power amplifier, which was specially made for this experiment.

The chamber can be operated in two modes. The water vapour flux can be controlled and the consequent evolution of the relative humidity measured, or the relative humidity can be controlled and the water vapour flux measured. The temperature can be controlled entirely independently of the moisture control. Proportional control is written into the program.

4. LIMITATIONS OF THE DESIGN

The instrument described here has proved to be reliable but has also shown some bad characteristics, which we describe here in sufficient detail that the interested reader can construct a better instrument.

The temperature control is made difficult by the high thermal inertia of the cooling coil. The cooling water is often only a few degrees cooler than the required well temperature, so one needs a large cold area, and therefore a large volume of water. The heating element, however, is at about four hundred degrees above the air temperature when activated. It is compact and has a very low thermal inertia. There is therefore a considerable asymmetry in the heating and cooling processes. The software proportional control algorithm must also follow a changing target temperature, for experiments which use a temperature cycle. In practice, the proportional control constants in the controlling script must be changed according to both the temperature range of the experiment and the cycle time. A more elegant control algorithm is needed.

The weighing system is working close to the limit of precision of strain gauge bridges - about one part per million. The smoothed average progress of the weight of water is of adequate precision for the scientific interpretation but the minute to minute variation makes it difficult for the program to calculate the correct voltage to apply to the thermoelectric heat pump. The program has to average over several minutes to predict a suitable voltage and is therefore bad at following a rapid cycle of flux or relative humidity. There should be some arrangement to counterbalance the nearly 1 kg weight of the empty tank and thermoelectric system, so that only the weight of water is measured.

The heat loss through the specimen puts an upper limit to the relative humidity that can be achieved without risking condensation on the walls of the chamber, as explained earlier. The risk of biological damage at high RH is the main postulated weakness of organic building materials. It is therefore important that the chamber can reach a high RH and control it accurately, to avoid transient episodes of condensation. The temperature uniformity of the walls is good but the floor of the well does not contribute to the cooling. It would be better to have a hollow floor connected to the annular space, though this would complicate the

construction, because all the services to the humidity controller are brought through the base of the chamber.

5. CONCLUSION

The climate chamber performs well as a research tool for measuring combined diffusion and absorption of water vapour through porous absorbent materials of low thermal conductivity held in a varying gradient of both temperature and water vapour concentration.

6. ACKNOWLEDGEMENTS

The construction of this apparatus was funded by the Danish Energy Agency. For technical help with construction we thank particularly: Martin Dandanell, Anders Brink, Bent Hansen, Lars Jørgensen and Klaus Myndal, all in the Department of Civil Engineering of the Technical University of Denmark.

7. NOTES AND REFERENCES

The data logger is a Hewlett-Packard HP34970A with measurement card HP34901A and relay card HP34903A.

The thermoelectric cooler is from Marlow Industries, Aberdeen House, South Road, Haywards Heath, West Sussex, UK RH16 4NG. Two DT12-6 units are used (now obsolete). They are 40 mm square by 4 mm thick. They dissipate up to 54W, 15V at 5.6A and give a maximum temperature depression of 66 degrees below ambient.

The strain gauges are 350 ohm constantan gauges on a plastic base. Supplier: Measurements Group UK Ltd, Stroudley Road, Basingstoke, Hants RG24 8FW, UK

Measured drawings, electrical circuits and control programs are described in detail at the internet address: www.natmus.dk/cons/tp/megacup/tinman.htm, or they can be obtained as pdf files from: tim@padfield.dk

CEN 2001, European Norm EN ISO 12572:2001, Hygrothermal performance of building materials and products - Determination of water vapour transmission properties.